

Powered by



CB18-12 ▶ 12V18Ah

CB18-12 is a general purpose battery up to 5 years in standby service or more than 260 cycles at 100% discharge in cycle service. As with all HENGLI batteries, all are rechargeable, highly efficient, leak proof and maintenance free.



► Specification

Cells Per Unit	6
Voltage Per Unit	12
Capacity	18Ah @ 20hr-rate to 1.75V per cell @25°C (77°F)
Weight	Approx. 5.1kg(11.22 lbs)
Maximum Discharge Current	270A(5sec)
Internal Resistance	Approx. 10 mΩ
Operating Temperature Range	Discharge: -15°C~50°C (5°F~122°F) Charge: -15°C~40°C (5°F~104°F) Storage: -15°C~40°C (5°F~104°F)
Nominal Operating Temperature Range	25°C±3°C (77°F±5°F)
Float Charging Voltage	13.5 to 13.8 VDC/unit Average at 25°C (77°F)
Recommended Maximum Charging Current Limit	5.1A
Equalization and Cycle Service	14.4 to 15.0 VDC/unit Average at 25°C (77°F)
Self Discharge	HENGLI Batteries can be stored for more than 6 months at 25°C (77°F). Please charge batteries before using. For higher temperatures the time interval will be shorter.
Terminal	L terminal to accept M5 nut & bolt
Container Material	ABS(UL 94-HB) & Flammability resistance of (UL 94-V0) can be available upon request.



IT1720HL22031803

VRLA batteries are certified by ISO 9001, ISO14001 and OHSAS18001.

► Dimensions :

Unit: mm

Overall Height (H)	Container height (h)	Length (L)	Width (W)
167±1.5	167±1.5	181±1.5	77±1.5

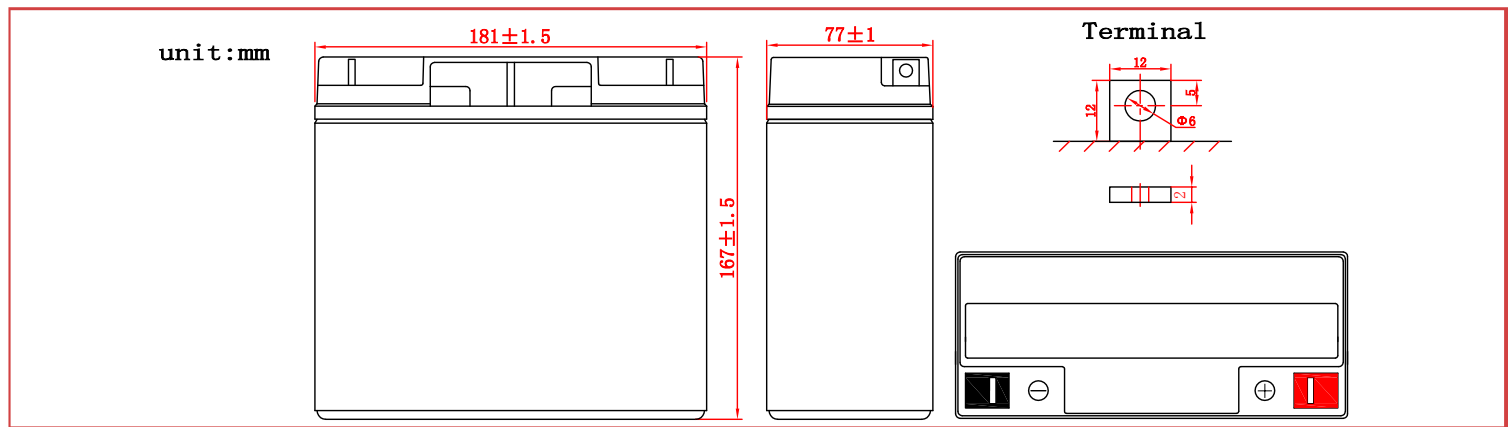

Constant Current Discharge Characteristics Unit:A (25°C, 77°F)

F.V/Time	5min	15min	30min	1h	3h	5h	10h	20h
1.60V	58.0	33.1	19.0	10.51	4.43	3.025	1.705	0.914
1.67V	56.9	32.2	18.8	10.39	4.40	3.001	1.697	0.910
1.7V	56.1	31.7	18.7	10.31	4.38	2.985	1.692	0.908
1.75V	53.4	30.2	18.3	10.04	4.30	2.934	1.674	0.900
1.8V	48.0	27.9	17.6	9.57	4.15	2.844	1.638	0.882
1.85V	37.2	23.5	16.2	8.76	3.78	2.648	1.548	0.846

Constant Power Discharge Characteristics Unit:W (25°C, 77°F)

F.V/Time	5min	15min	30min	1h	3h	5h	10h	20h
1.60V	99.3	63.3	36.7	19.98	8.74	5.903	3.355	1.810
1.67V	94.9	60.3	36.5	19.80	8.66	5.879	3.336	1.805
1.7V	91.8	58.2	36.3	19.68	8.62	5.856	3.326	1.802
1.75V	83.9	53.8	35.6	19.36	8.47	5.761	3.283	1.787
1.8V	72.3	47.9	34.3	18.73	8.16	5.567	3.215	1.752
1.85V	56.3	40.2	31.6	17.40	7.52	5.272	3.062	1.687

Ratings presented herein are subject to revision without notice. Please refer to www.baacebattery.com and www.hengli.cn to confirm the latest version.

Trickle(or Float)Design Life

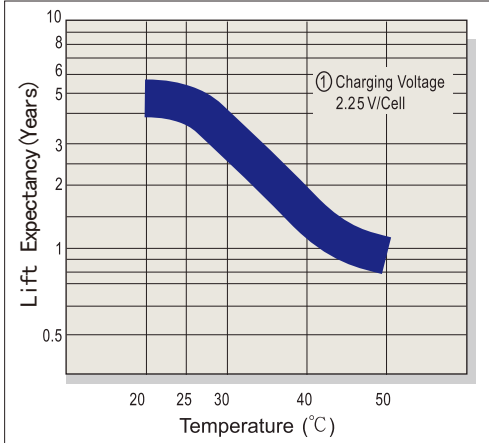

Capacity Retention Characteristic

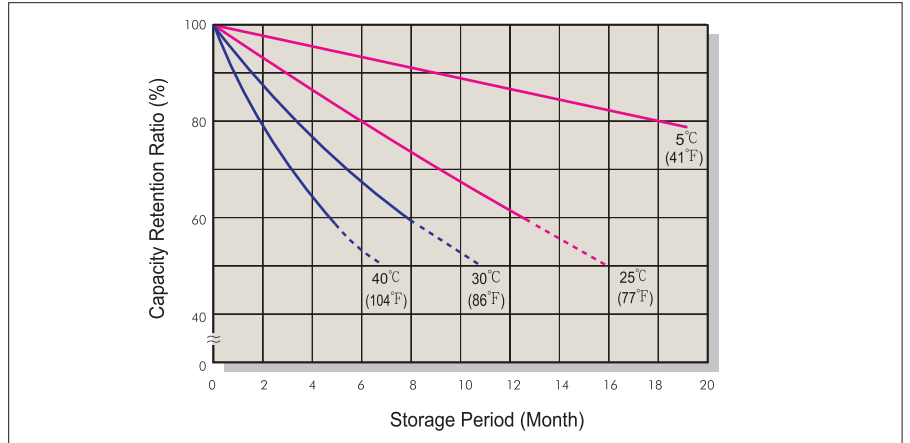

Battery Voltage and Charge Time for Standby Use

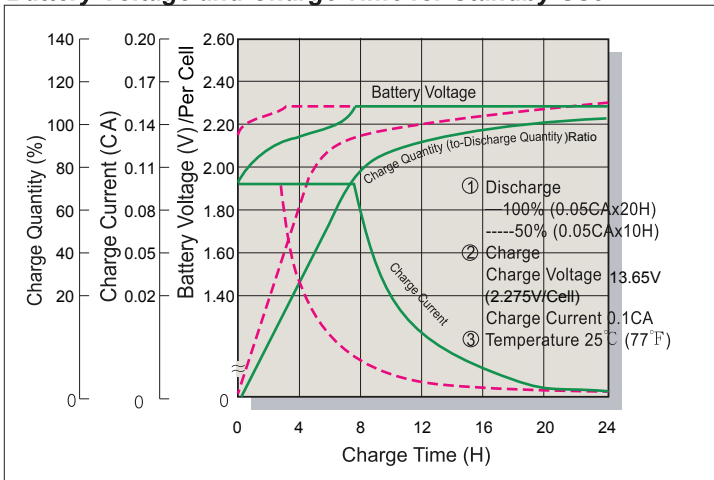

Cycle Service Life

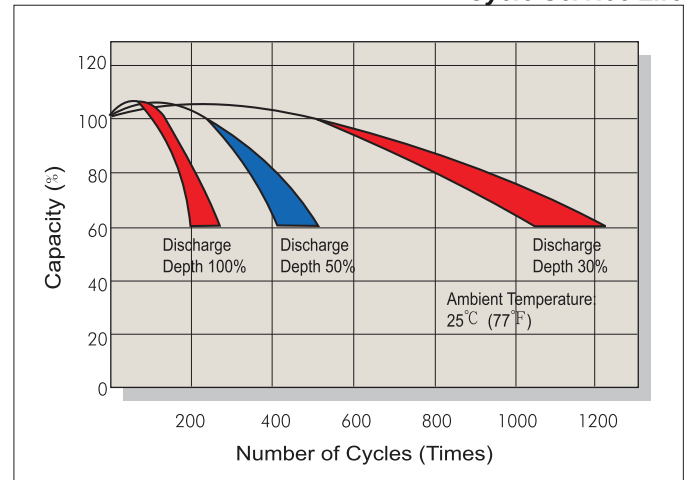

Battery Voltage and Charge Time for Cycle Use

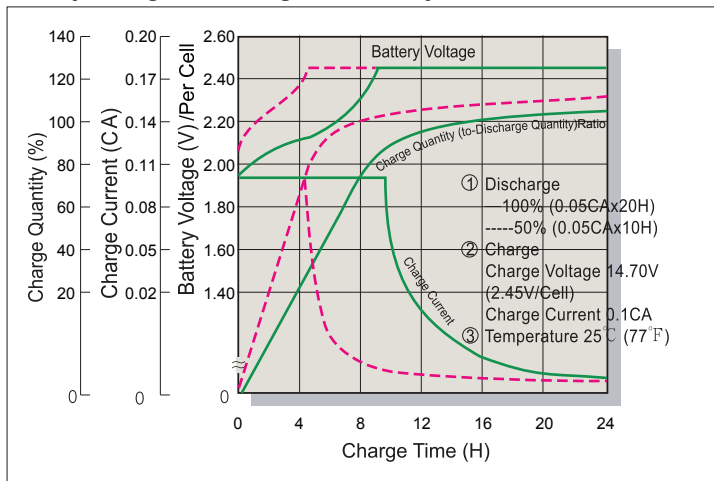

Terminal Voltage (V) and Discharge Time

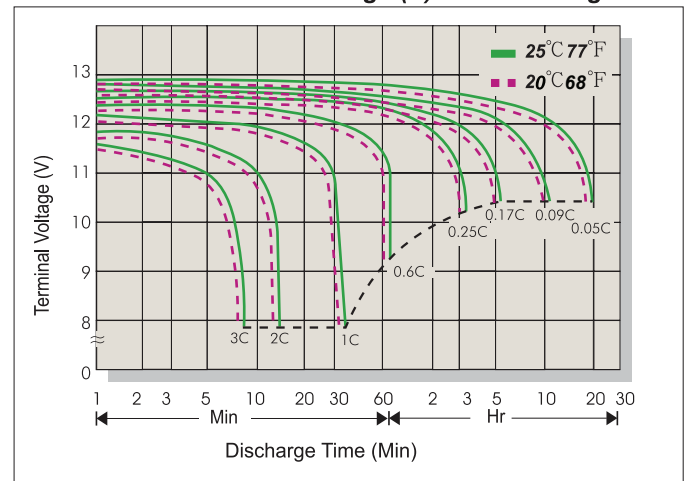

Charging Procedures

Application	Charge Voltage(V/Cell)			Max.Charge Current
	Temperature	Set Point	Allowable Range	
Cycle Use	25°C (77°F)	2.45	2.40~2.50	0.3C
Standby	25°C (77°F)	2.275	2.25~2.30	

Discharge Current VS. Discharge Voltage

Final Discharge Voltage V/Cell	1.75	1.70	1.65	1.60
Discharge Current(A)	0.2C>(A)	0.2C<(A)<0.5C	0.5C<(A)<1.0C	(A)>1.0C

Effect of temperature on capacity (20HR)

Temperature	Dependency of Capacity (20HR)
40 °C	102%
25 °C	100%
0 °C	85%
-15 °C	65%

Self-discharge Characteristics

Storage time	Preservation rate
3 Months	91%
6 Months	82%
12 Months	64%